

# SCANIA

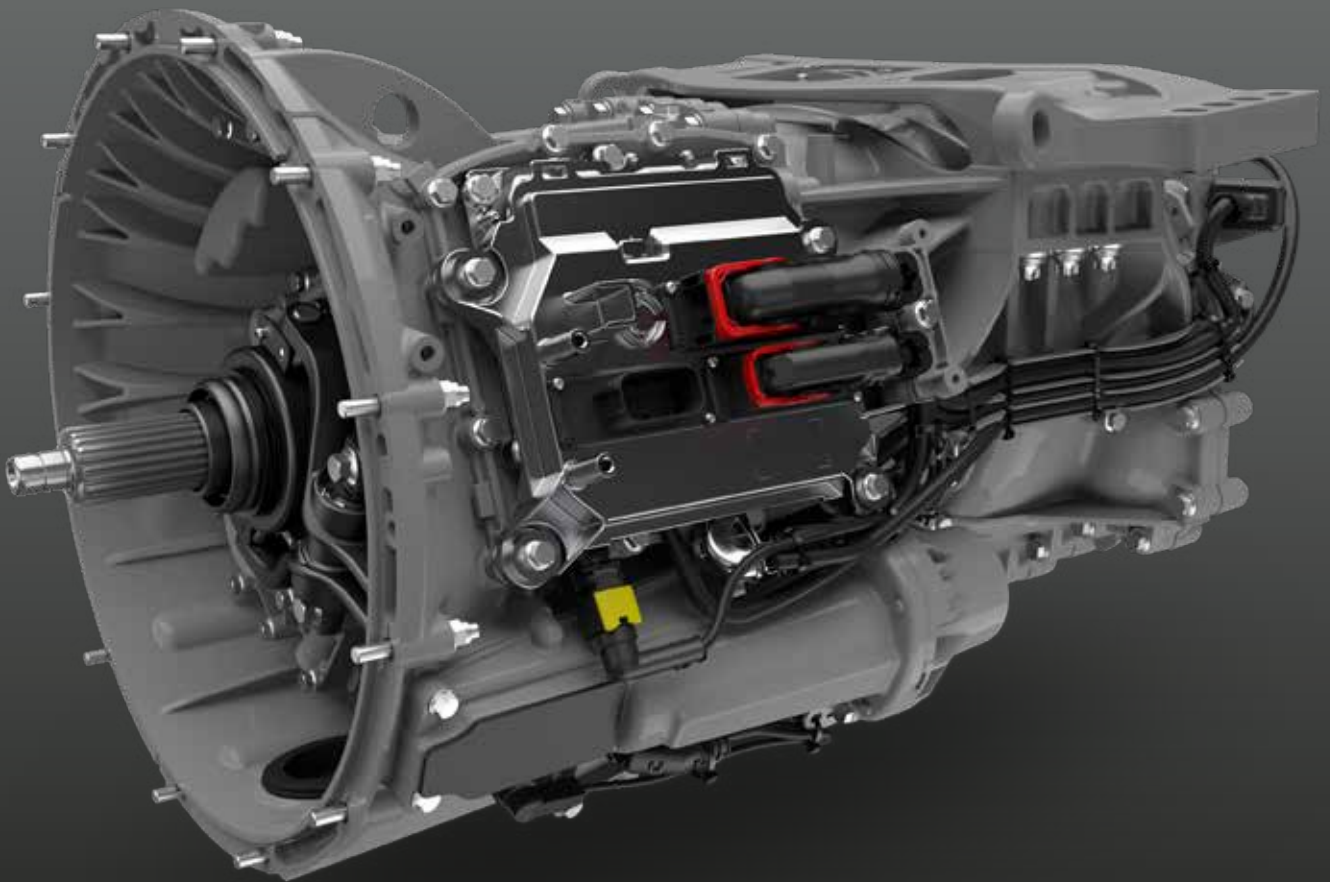

SCANIA OPTICRUISE GEARBOX G25, G33 & G38

# PERFORMANCE ON A NEW LEVEL



# OPTICRUISE G25, G33 & G38

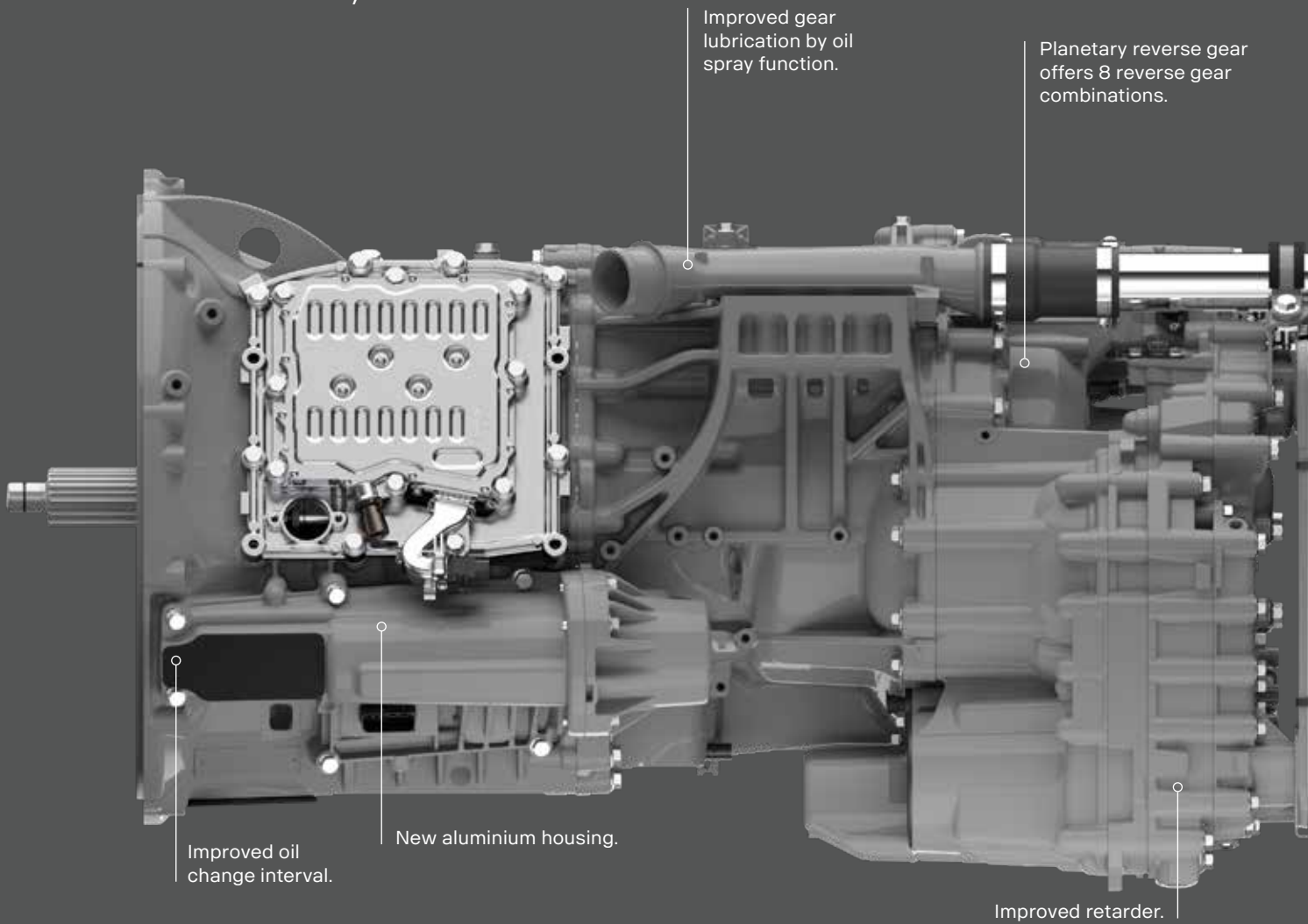

GRS0905, GRS0926 and GRS0935
  GRS905
  G25 , G33 and G38

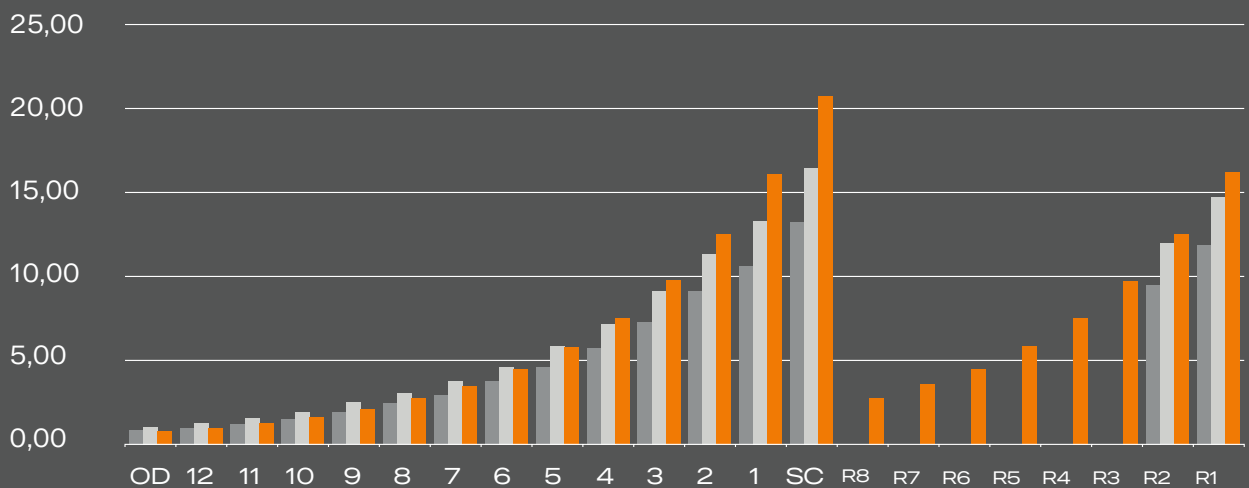

The heavy-duty G25, G33 and G38 Opticruise features wider planetary gears to deliver higher output torque and ensure the Opticruise's extended service life even in tough operations.

New PTO program.

Reduced length up to 200 mm.



## A NEW BENCHMARK FOR GEARBOX EFFICIENCY

Industry-leading engine performance demands a highly-efficient gearbox. The Opticruise G25, G33 and G38 gearbox range, available as a standard or heavy-duty option, is the industry's leading gearbox choice for sustainable, fuel-efficient transport operations.

Lighter, more robust, and offering a wider gear ratio spread – the new Opticruise range sets a new industry benchmark for gearbox performance. The transfer of power across the powertrain is not only remarkably efficient, it's almost seamless.

### **Unrivalled startability and fuel efficiency**

The introduction of the Scania Opticruise G25 and G33 means that you no longer need to compromise on startability performance or fuel efficiency when it comes to your transport operations.

The three gearboxes G25, G33 and G38 are identical in regards to the technical build up but are adapted to different engine torques. With a wider gearing,

the new gearboxes enable the Scania low-rev cruising philosophy with impressive fuel savings when compared to existing best-in-class alternatives.

We offer 14 forward gears, including a super crawler and overdrive gear, as well as up to 8 reverse gears with improved driveability. This opens up a wider range of possibilities for many applications.

# TECHNICAL HIGHLIGHTS

## Improved gear options

Based on a wider and more efficient 14-gear ratio, the control system of the Scania Opticruise G25, G33 and G38 will automatically select the optimum gear for every driving situation. The new Opticruise performance steps, with super crawler and overdrive as standard, are engineered to support a higher torque at lower engine rpm – delivering lower fuel consumption. The Scania Opticruise also delivers improved reversing performance, featuring four automated-shift reverse gears as a standard, with the option of eight reverse gears in total.

## Outstanding efficiency

Through a new variable oil volume and oil spray system, the Scania Opticruise G25, G33 and G38 offer improved oil-flow distribution, ensuring less internal friction and contributing to 50% lower internal losses.

## Quieter, lighter, more compact

Through low weight cast aluminium housing and a new compact, robust design, the G25/G33/G38 Opticruise' delivers significant weight savings compared to predecessor platforms. It's also Scania's quietest gearbox platform yet – lowering sound levels by 3.5 decibels.

## Superior uptime

Through higher precision engineering and the use of larger oil filters and high-quality oil, the Scania Opticruise G25, G33 and G38 offer an extended oil change interval. This is supported by additional maintenance improvements, such as oil level sensors that detects possible oil leakage, and oil temperature sensors that creates a monitoring function.

## Improved driveability

The Opticruise gearbox is equipped with a robust management system which is designed to adapt to the current vehicle operation to enable smoother gear shifting, lower fuel consumption and a more comfortable driving experience.

## Improved retarder performance

The hydraulic auxiliary brake is enhanced through improved retarder performance, ensuring a maximum brake torque of 4700 Nm. When not in use, the Scania retarder can be disengaged to improve the powertrain's efficiency.

## Improved PTO performance

The Scania Opticruise G25, G33 and G38 introduce a more powerful, fuel-efficient, low-noise and low-weight clutch-driven power take-off (PTO) range, delivering even higher continuous power output and supporting heavier equipment together with one pump and five different flange interfaces.

## Superior heavy-duty performance

Featuring wider planetary gears, the heavy-duty G25, G33 and G38 Opticruise is engineered to deliver higher output torque, superior startability and fast axle gearing in challenging conditions and topographies. Optimised for high payloads in tough operations, the heavy-duty gearbox range also ensures the Opticruise's extended service life – keeping your trucks on the off-road for longer.

## WEIGHT SAVINGS ON PREDECESSOR

GRS0905/  
GRS0926

G25CM (standard)	75 kg
G33CM (standard)	60 kg
G38CM (standard)	60 kg

GRS0935

G25CH (heavy-duty)	95 kg
G33CH (heavy-duty)	80 kg
G38CH (heavy-duty)	80 kg

## ENGINE SPECIFICATIONS

	Torque	Engine
G25	2500 Nm	220 hp – 460 hp
G33	3300 Nm	500 hp – 660 hp
G38	3800 Nm	770 hp







